

**Question:**

Examine the synthesis below before answering the questions. Each arrow depicts a single step.

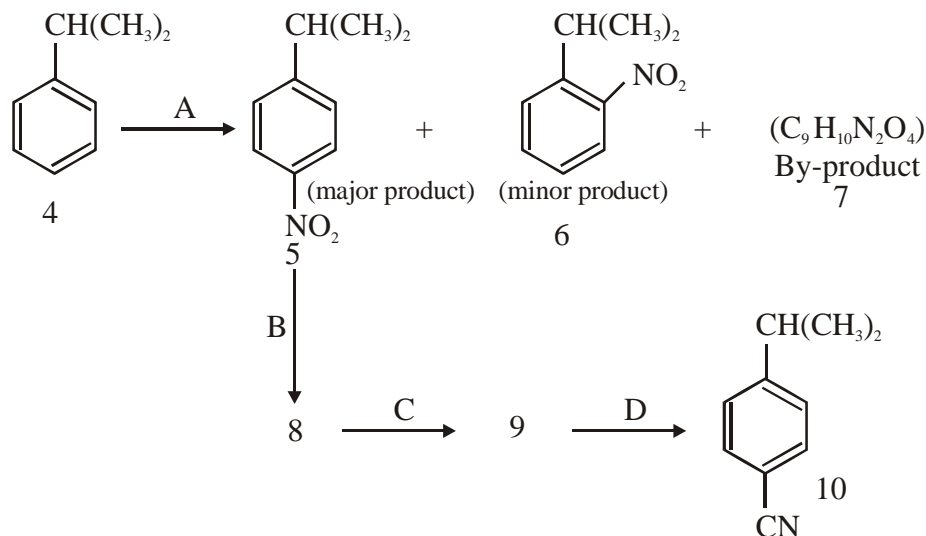

- Give the reagent(s) required for transformation of compound 4 into 5 (reaction A).
- Draw out a complete reaction mechanism (and include formation of the electrophilic agent) using curly arrows to show how the starting material 4 is transformed into the major product 5, and including the structures of any intermediates that are involved.
- Explain why the *para* isomer 5 and *ortho* isomer 6 are formed as the products and why the *para* isomer 5 is the major product. (*Hint* : there is no need to draw any structures here.)
- If reaction A is allowed for a long time, a long time, a by-product 7 is increased and found to have the following formula: C<sub>9</sub>H<sub>10</sub>N<sub>2</sub>O<sub>4</sub>. Predict the structure of compound 7.
- Deuce the structures of the intermediate products 8 and 9 in the conversion of compound 5 into compound 10. Give all the reagents needed to bring about each individual B, C and D.

## ANSWERS

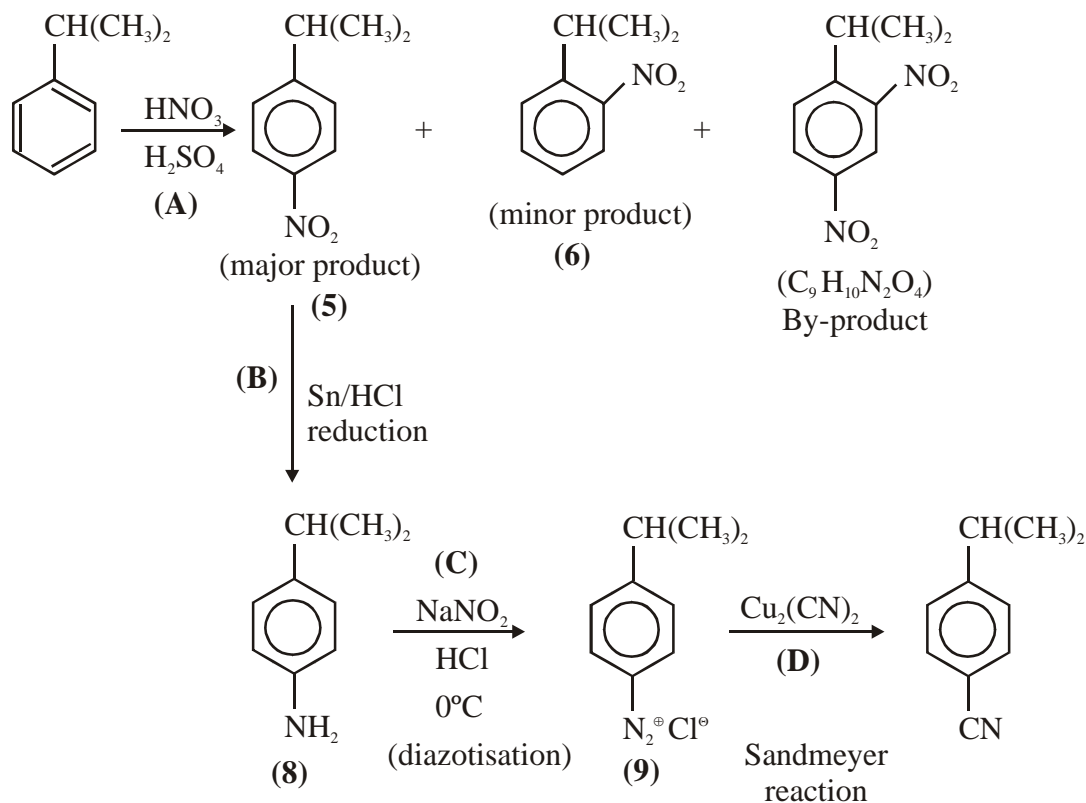

- (a) The reagent required for transformation of compound 4 into 5 (reaction A) is nitrating mixture.
- Nitrating mixture is  $\text{HNO}_3 + \text{H}_2\text{SO}_4$ . Even fuming nitric acid can also be taken.

(b) **Reaction :**

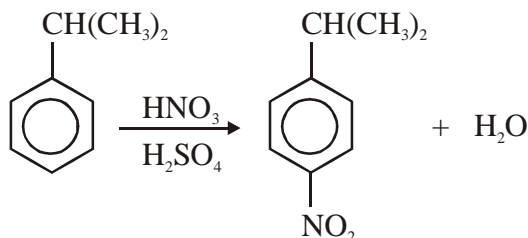

The reaction follows electrophilic substitution reaction mechanism. It occurs in three steps.

**Step 1 :** Generation of electrophile

## Mechanism

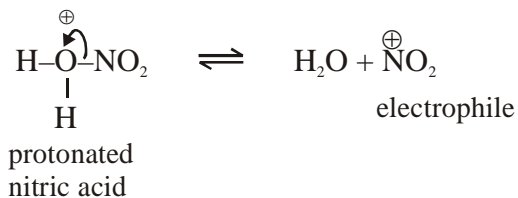
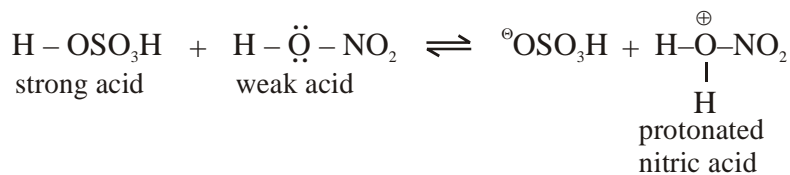
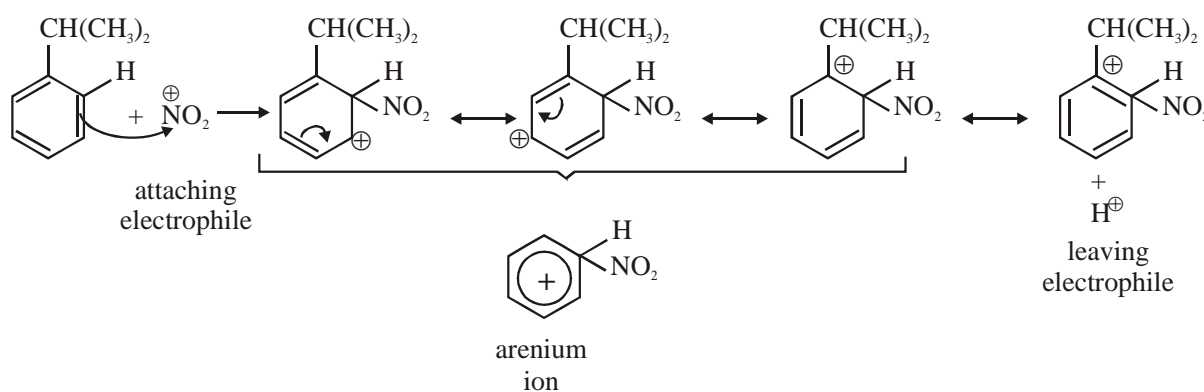
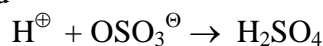
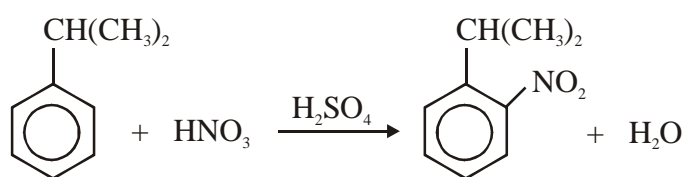
**Step 2 :** Generation of arenium ion**Step 3 :** Generation of Lewis acid**Overall reaction**

- (c) *Ortho* and *para* product are formed as major product as  $(\text{CH}_3)_2\text{CH}-$  group is *ortho* and *para* directing.

*Para* product is formed as a major product, due to  $\text{NO}_2^\oplus$  electrophile is effected by steric hinderance. offered by bulky  $(\text{CH}_3)_2\text{CH}-$  group.

- (d) The structure of compound  $\text{C}_9\text{H}_{10}\text{O}_4$  is

## Mechanism

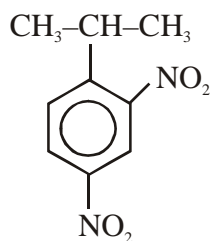

2,4-dinitrocumene

As reaction is allowed to stand for some time than mono substituted benzene ring, further undergoes electrophilic substitution, leading to formation of di substituted benzene derivative, moreover the directing effect of  $(\text{CH}_3)_2\text{CH-}$  and  $-\text{NO}_2$  reinforce each other. The incoming  $\text{NO}_2$  group attaches as directed below.

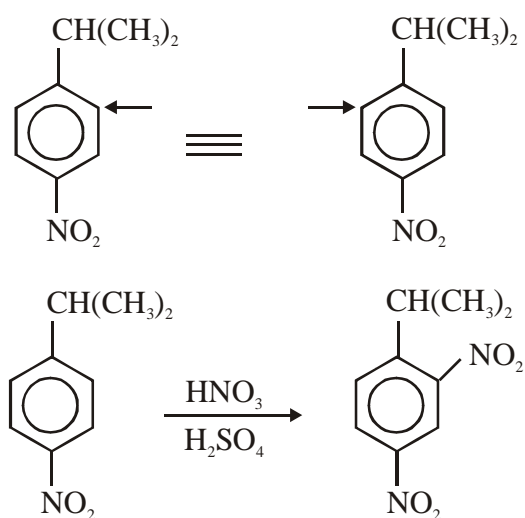

- (e)  $-\text{NO}_2$  is sensitive towards reduction, hence on treatment with Sn in HCl,  $\text{NO}_2$  group is reduced to  $\text{NH}_2$  group.

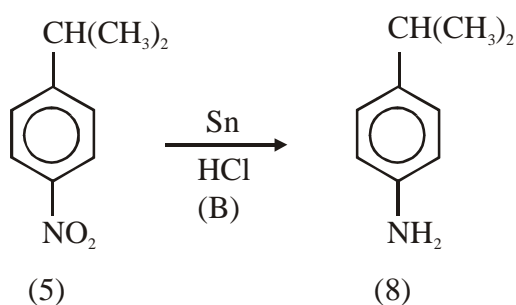

$\text{NH}_2$  group can easily be diazotised using  $\text{NaNO}_2$  in HCl at  $0^\circ\text{C}$ .

## Mechanism

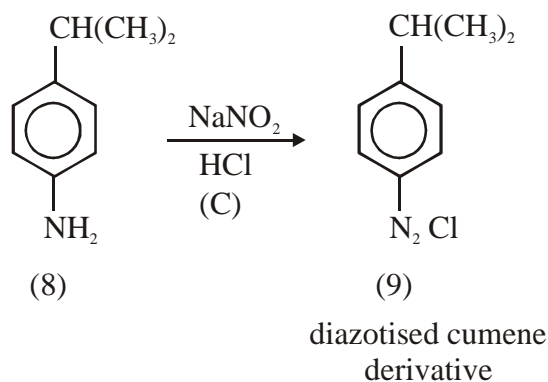

– N<sub>2</sub>Cl group can easily be converted to –CN group by Sandmeyer Reaction.

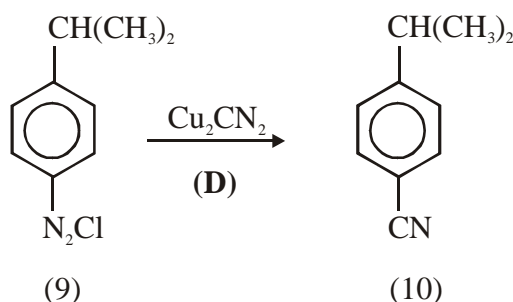
**Question**

When 3-bromoprop-1-ene **1** is treated with HBr, it yields compound **2** as the major product, which, when treated with zinc dust; gives compounds **3**.

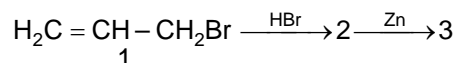

- (a) What are the structural formulae of the compounds **2** and **3** ?
- (b) Write a mechanism, using curly arrows, to account for the formation of each compound. Explain your reasoning in each case.

**Explanation :**

1. Addition of HBr on alkene occurs according to MARKONIKOF REACTION which is example of electrophilic addition mechanism.

HBr ionizes to give H<sup>+</sup> ion as electrophile. It can attack double bond of alkene by two possibilities.

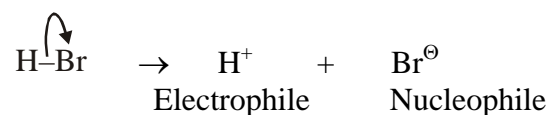

Possibilities are :

## Step A:

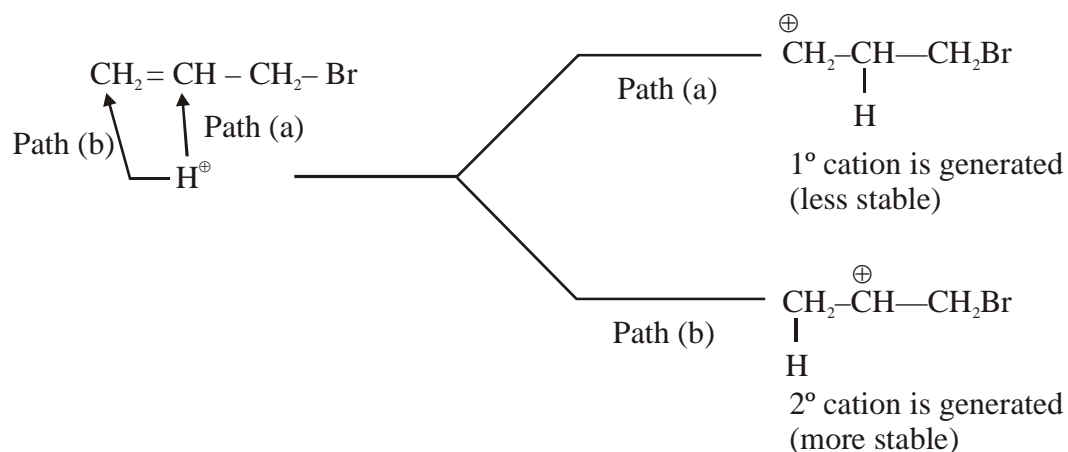

Hence path b is followed.  
Using curved arrows.

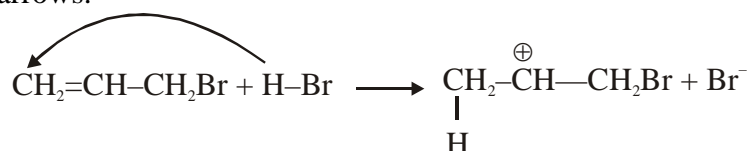

**Step B :** Nucleophile  $\text{Br}^-$  ion now attacks secondary carbo cation.

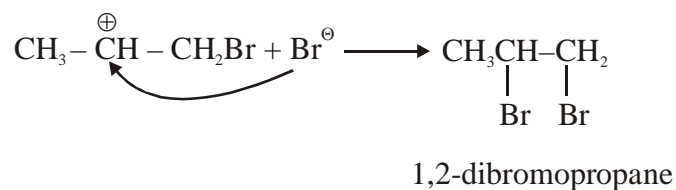

2. Zn forms  $\text{ZnBr}_2$  and due to elimination of 2 Br atom present at adjacent C atoms, a double bond is formed.

